



EM-E-1999-FI/FVZ



EM-E-1930-EST

Aufprallfläche		
	Deutschland	Europa
Aufprallfläche	22,30 m ²	22,30 m ²
davon Fallschutz Bodenmaterial Nr. 6-9 Schichtdicke 30 cm	22,30 m ²	22,30 m ²
davon Fallschutz Bodenmaterial Nr. 6-9 Schichtdicke 40 cm	-	-
davon Rasen Bodenmaterial Nr. 5	-	-
Fallschutzplatten Bodenmaterial Nr. 10	-	-
Freie Fallhöhe	60 cm	60 cm
Gerätehöhe	100 cm	100 cm

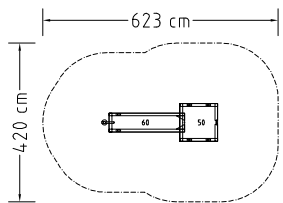



M= 1:200

 2 Monteure
a ca. 100 Min.



besonders geeignet für
Kinder von
2-9 Jahren

Beschreibung	
Matschanlage, EM-E-1999-* - Wasserspender, EM-E-1930-EST - Wasserrinne Länge 200 cm - Matschtisch, 4-eckig - Wasserschieber aus PE	Wasserspender, EM-E-1930-EST - zum Anschluß an eine Frischwasserleitung - Wasserabsperrung über selbstschließenden Druckspüler - Gehäuse komplett aus Edelstahl - zum Einbetonieren, mit Montageflansch

 **EM-E-1999-***
6 x 40 x 40 x 95
1 x 50 x 50 x 70
EM-E-1930-*
1 x 50 x 50 x 70

 **EM-E-1999-***
6 x 40 x 40 x 45
1 x 50 x 50 x 60
EM-E-1930-*
1 x 50 x 50 x 60

Matschanlage & Wasserspender	
EM-E-1999-FI/FVZ	Fichte kernfrei, kesseldruckimprägniert Rinnenstandpfosten feuerverzinkt Mehrpreis Lärche kernfrei, natur
-E- -LAE	
EM-E-1930-EST	Wasserspender

 **EM-E-1999-***
20 x 50 x 200
EM-E-1930-*
20 x 35 x 100
EM-E-1999-*
30
EM-E-1930-*
20

*alle Preise zzgl. ges. MwSt